

JONSSON

COMPACT SHRIMP PEELER

This compact automatic shrimp peeling machine is designed for restaurants, seafood markets and other food service operations with limited floor space.



Tail on butterfly



Tail on round



Completely peeled and deveined



Completely peeled and deveined, split



EZ peel



FEATURES

- 10 times faster than hand peeling.
- Provides unsurpassed uniformity and product quality.
- Less handling means cleaner peeled shrimp.
- Cuts lead time so you serve the freshest product.
- Peel any size from 10 to 90 count.
- Peel any kind: all warm water shrimp, wild or pond raised, fresh or previously frozen.
- Peel these styles: tail on or tail off: choose round, butterfly or EZ peel.

BENEFITS

Peels Faster

- Meet peak demands easily without additional personnel.
- Easy to operate, paces the operator at a high, comfortable rate of 3000 shrimp per hour.

Peel better

- Uniform cut means you serve the most attractive looking shrimp.
- Patented systems guarantee every shrimp is cut down the middle at the exact same depth.

Peels cheaper

- Can significantly reduce labor costs.
- Takes up less than 4 square feet of floor space. Rolls out of the way when peeling is completed.
- Corrosion resistant and food approved materials.
- Open design provides access for cleaning and maintenance.
- Less handling means shrimp contamination is minimized.

Productivity Shown In Pounds per Hour		
Input of Raw Headless Shrimp		
Shrimp Size No. Per LB.	Machine Speed	
	Maximum	Realistic
10/15 count	250 lbs.	170 lbs.
16/20	170	115
21/25	130	90
26/30	110	75
31/35	90	60
36/40	80	55
41/50	65	45
51/60	55	35
61/70	45	30
71/90	40	25

Column 1 shows the maximum machine speed of 3,000 per hour.

Column 2 shows actual, achievable, experience based productivity of 2,000 per hour.

The larger the shrimp, the greater the productivity in pounds.

Production will be less than machine speed because of the time required to empty peeled shrimp and shell boxes.

For our customers who need to peel tail-on western style, we have a machine that will peel all the styles listed above, plus western. Ask us for details.

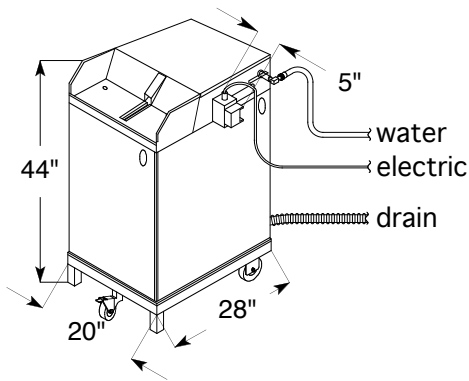

Water

- 35 to 45 gallons per hour
- 30 to 50 psi pressure
- Floor drainage is required

Electricity

- Standard electric is 115 volt, 60 Hz.
- 1/3 hp motor draws 5.6 amp.
- Can be wired for 220 volt, 50 Hz.

Weight

- 325 pounds net, 420 pounds shipping

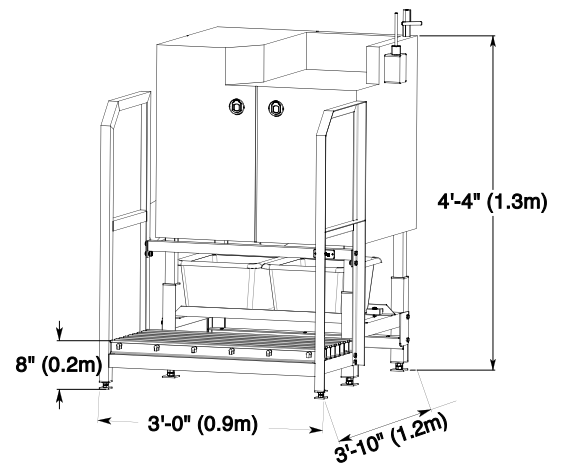

If your peeling needs approach full time use and you have the space available, you can save more by using a Jonsson model designed for greater production. Any full size Jonsson model can be placed on a 16000 Jonsson Individual Platform to speed peeling. It will not speed inspection or any hand work that may be required, and therefore will never be as great a value as a complete Jonsson system.

13822 LAUREL DRIVE
LAKE FOREST, IL 60045 USA
PHONE 847.247.4200
FAX 847.247.4272
WEB www.jonsson.com
EMAIL sales@jonsson.com

GREGOR
JONSSON
INC.
SHRIMP PEELING SYSTEMS